

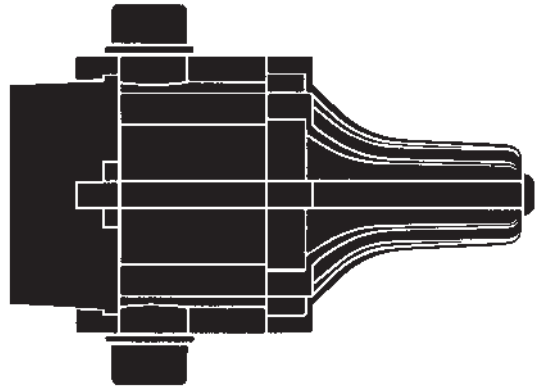

# AUTO RESTART PUMP CONTROL

ELECTRONIC REGULATOR FOR ELECTRIC PUMPS

**WHI-SK20PPHS2 (2.2 bar Start Up)**

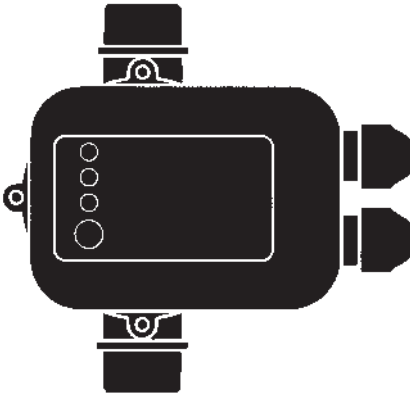

## SPECIFICATIONS

Input Voltage 240V

Frequency 50Hz

Current Max. 16A

Protection Rating IP65

Maximum working pressure 10bar

Max working temperature 60°C

Connection 1" male BSP

# INSTRUCTIONS FOR CORRECT UNIT INSTALLATION

If the column of water between the pump and the highest tap exceeds 20m, the unit cannot be installed directly on the pump, but it has to be raised until the column of water between the unit and the highest tap does not exceed 20m. i.e. If column of water is 25m from the pump, the unit must be placed 5m higher than the pump.

Installation and maintenance of the controller must be performed by a qualified professional.

The unit is equipped with a check valve to prevent the pipeline from losing pressure.

**NO** taps can be installed between the pump and the unit.

## PUMP'S PRESSURE

The unit is pre-set by the manufacturer at a restarting pressure of 2.2 bar.

The pressure produced by the pump must be normally 0.8 bar higher than the pre-set pressure.

Before starting the unit check suction and ensure that the pump is primed.

It is advisable to connect the unit outlet to the system by means of a flexible hose.

Safety valve preventing water emission in case of diaphragm breaks

**DO NOT TOUCH**

It is imperative to install the unit with the arrows in the upwards position.

The unit can be installed directly on the pump, or between the pump and the first tap.

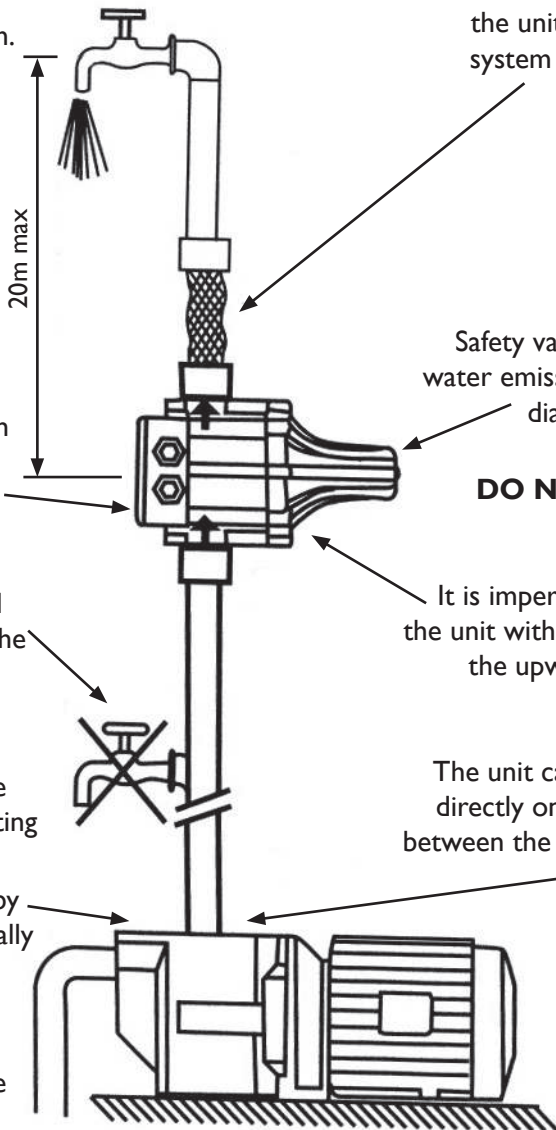

# WIRING DIAGRAMS FOR CONNECTING THE UNIT TO DIFFERENT KINDS OF PUMP MOTORS

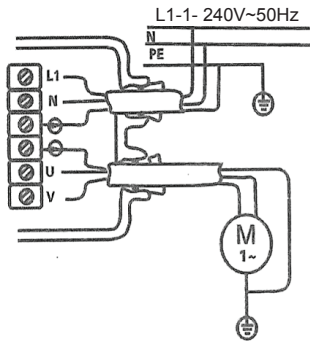

Wiring diagram for connection of single phase 240V pumps up to 1.5kW.

<b>POSSIBLE WORKING DEFECTS</b>		
<b>TYPE OF DEFECT</b>	<b>CAUSES DEPENDING ON THE UNIT</b>	<b>CAUSES NOT DEPENDING ON THE UNIT</b>
The pump does not start	The electronic card is broken	Voltage failure Pump jammed Electric cables inverted (line/ motor)
The pump does not stop	The electronic card is broken The flow detector is blocked in the upper position The reset button is blocked The pump does not provide sufficient pressure	Presence of leaks which are higher than the minimum flow of 0.6 l/ min
Intermittent pump working	The electronic card is broken The pump does not provide sufficient pressure	Presence of leaks which are lower than the minimum flow of 0.6 l/ min
The pump is jammed	The electronic card is broken The pump provides a pressure which is lower than the restarting pressure	Water failure Suction problems

# UNIT STARTING AND WORKING

## Warning

Never take the electronic board out of the control box.

The wiring diagram inside the terminal block will show you how to correctly wire the controller. Wrong connection will destroy the whole electronic circuit.

Cable used for connection must be a three-wired one with compulsory grounding end. It shall have the outer diameter at 7.5mm min and 8.5mm max. One of the leading end of the cable must be lower than the position of the fixing screws while the cable being connected to the power as shown in the Figure below.

The four screws on the panel board and the two nuts for fixing cable must be well fastened to avoid water entering into the control box and damaging the electronic circuit.

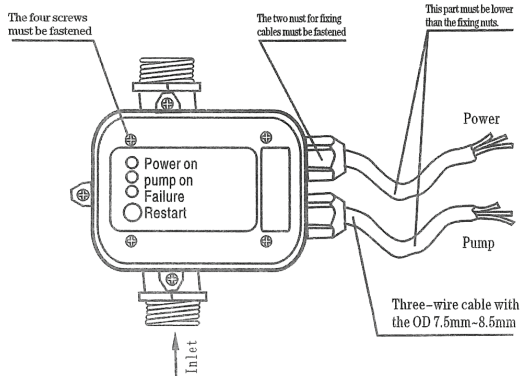

## STARTING

When the unit is connected to the electrical network, the green led "Power On" lights up and the yellow led "On" (pump in operation) 2 seconds later indicating that the pump has been started.

The pump continues to operate for dozens of seconds enabling the system to fill in the pipes and reach the required pressure.

If this lapse is insufficient, the red led "Failure" lights up. In this event, keep the "Restart" button pressed and wait, with a tap opened, until the red led is off.

Once the button is released the tap is closed, the unit stops the pump at its maximum pressure.

## FUNCTIONING

This unit is programmed to perform all the pump control operation automatically.

If no water is supplied to the system, i.e no water in tank or closed supply/suction pipe, the system will run the following sequence: Switch off after 20 seconds if no water is detected, stop for 10 seconds, run for 40 seconds stop for 10 seconds, run for 40 seconds stop for 10 seconds. The controller at this point will go into run dry protection. The power light will stay illuminated and the Failure light will flash slowly after this time. When the failure light is flashing, it means the pump will restart after 24 hours in the sequence mentioned above. The system will repeat this every 24 hours until water is detected.

The pump can be restarted at any time by pressing the reset button.